

Matrix[®] AP

208V – 690V

INSTALLATION GUIDE

FORM: MAP-IG-E
REL. June 2020
REV. 005
© 2020 MTE Corporation



High Voltage! Only a qualified electrician can carry out the electrical installation of this filter.

Quick Reference

1	How to Install	Pages 7 – 22
2	Startup/Troubleshooting	Pages 23 – 28

This page intentionally left blank

TABLE OF CONTENTS

1. SAFETY	4
WARNINGS AND CAUTIONS	4
GENERAL SAFETY INSTRUCTIONS	5
2. INTRODUCTION	6
RECEIPT & REPAIR STATEMENT.....	6
WARRANTY	6
3. HOW TO INSTALL	7
INSTALLATION CHECKLIST	7
GROUNDING	8
OVER TEMPERATURE INTERLOCK	9
POWER WIRING CONNECTION	10
BASIC SCHEMATIC DIAGRAM	11
OPEN PANEL UNIT INTERCONNECTION DIAGRAM	12
ENCLOSED UNIT INTERCONNECTION DIAGRAM	13
CONTACTOR OPTIONS.....	14
CONTACTOR COIL SWITCHING CURRENTS.....	18
TORQUE RATINGS MATRIX AP 208V-240V.....	19
TORQUE RATINGS MATRIX AP 380V-415V, 480V, 600V.....	20
TORQUE RATINGS MATRIX AP 690V	22
4. START UP	23
STARTUP CHECKLIST	23
5. TROUBLESHOOTING	25
MATRIX AP HARMONIC FILTER FIELD CHECKS.....	27

List of Figures

Figure 3-1: Basic Schematic Diagram	11
Figure 3-2: Open Panel Interconnection.....	12
Figure 3-3: Enclosed Interconnection.....	13
Figure 3-4: Contactor Options – 002	14
Figure 3-5: Contactor Option – 009.....	15
Figure 3-6: Contact Option – 012	16
Figure 3-7: Contact Option – 013	17



List of Tables

Table 3-1: Over Temperature Switch	9
Table 3-2: Contactor Coil Switching Currents.....	18
Table 3-3: Torque Ratings 208V-240V.....	19
Table 3-4: Torque Ratings 380V-415V, 480V, 600V	20
Table 3-5: Torque Ratings - 690V	22
Table 5-1: Performance Specifications.....	26
Table 5-2: Troubleshooting Guide.....	28



1. SAFETY

Warnings and Cautions

There are three types of warnings in this manual:

 WARNING	High Voltage Warning: warns of situations that dangerously high voltage is involved. Failure to use proper precautions may lead to serious injury or even death.
 WARNING	General Warning: warns of situations that can result in serious injury or death if proper precautions are not used.
 Caution	General Caution: identifies situations that could lead to malfunction or possible equipment damage.

General Safety Instructions

 WARNING	<p>High Voltage! Only a qualified electrician can carry out the electrical installation of this filter.</p>
 WARNING	<p>High voltage is used in the operation of this filter. Use extreme caution to avoid contact with high voltage when operating, installing or repairing this filter. Injury or death may result if safety precautions are not observed.</p> <p>The opening of the branch circuit protective device may be an indication that a fault current has been interrupted. To reduce the risk of fire or electrical shock, current-carrying parts and other components of the filter should be examined and replaced if damaged.</p> <p>An upstream disconnect/protection device must be used as required by the National Electrical Code (NEC) or governing authority.</p> <p>Even if the upstream disconnect/protection device is open, the drive down stream of the filter may feedback high voltage to the filter. The drive safety instructions must be followed. Injury or death may result if safety precautions are not observed.</p> <p>The filter must be grounded with a grounding conductor connected to all grounding terminals. Open panel filters must have reactor grounded through a 2"x2" area cleaned of paint and varnish on lower mounting bracket.</p> <p>Only spare parts obtained from MTE Corporation or an authorized MTE distributor can be used.</p> <p>After removing power, allow at least five minutes to elapse and verify that the capacitors have discharged to a safe level before contacting internal components. Connect a DC voltmeter across the capacitor terminals and ensure that the voltage is at a safe level.</p>
 Caution	<p>Loose or improperly secured connections may damage or degrade filter performance. Visually inspect and secure all electrical connections before power is applied to the filter.</p> <p>The user of this filter must assure that the input voltage and frequency is correct for the filter rating and that the voltage applied falls within the rated operating tolerance envelop specified for the filter. For sever power line applications where the power feed is likely to experience surges and transients that exceed the input voltage rating, it is recommended that a TVSS (Transient Voltage Surge Suppression) or SPD (Surge Protection Device) be deployed ahead of the filter to reduce the possibility of exceeding the filter rated voltage. Consult with TVSS or SPD manufacturer to determine the correct protection requirements for your power line conditions.</p>

2. INTRODUCTION

The purpose of this manual is to aid in the proper installation of the Matrix AP.

For most current product information, including technical reference manual, please refer to website:

www.mtecorp.com/products/matrix-ap-harmonic-filters/

This manual is intended for use by personnel experienced in the operation and maintenance of drives. Because of the high voltages required by the filter, drive and the potential dangers presented by rotating machinery, it is essential that all personnel involved in the operation and maintenance of this filter know and practice the necessary safety precautions for this type of equipment. Personnel should read and understand the instructions contained in this manual before installing, operating or servicing the filter and drive to which it is connected.

Receipt & Repair Statement

Upon Receipt of this Filter:

The Matrix AP Harmonic Filter has been subjected to demanding factory tests before shipment. Carefully inspect the shipping container for damage that may have occurred in transit. Then unpack the filter and carefully inspect for any signs of damage. Save the shipping container for future transport of the filter.

In the event of damage, please contact and file a claim with the freight carrier involved immediately.

If the equipment is not going to be put into service upon receipt, cover and store the filter in a clean, dry location. After storage, ensure that the equipment is dry and that no condensation or dirt has accumulated on the internal components of the filter before applying power.

Repair/Exchange Procedure

MTE Corporation requires a Return Material Authorization Number and form before we can accept any filters that qualify for return or repair. If problems or questions arise during installation, setup, or operation of the filter, please contact MTE for assistance at:

Toll Free: 1-800-455-4MTE (1-800-455-4683)

International Tel: +1- 262-253-8200



Fax: +1-262-253-8222

Warranty

Three years from the date of shipment. See www.mtecorp.com for details.

3. HOW TO INSTALL

Installation Checklist

 WARNING	<p>Prior to installation, please refer to all general warnings on page 5. Failure to practice this can result in body injury!</p>
	<p>Input and output wiring to the filter should be performed by authorized personnel in accordance with NEC and all local electrical codes and regulations.</p>
 WARNING	<p>The filter is designed for use with copper conductors with a minimum temperature rating of 75 degrees C.</p>
	<p>Do not install capacitor assembly above/near the Harmonic Mitigating Reactor. Premature or catastrophic failure may occur.</p>

Matrix AP Filters are supplied in the following mechanical configurations:

- Open Panel Mount
- Floor mounted general purpose NEMA 1/2, & NEMA 3R cabinets

Select a well-ventilated area suitable for the NEMA enclosure type number. Do not install in or near a corrosive environment. Avoid locations where the filter would be subjected to excessive vibrations.

Open panel filters are designed for mounting within the customer’s enclosure. Open panel units consist of a Harmonic Mitigating Reactor (HMR) and one or more capacitor panel modules referred to as cap-panels on drawings and diagrams.

The capacitor panel must be located in the lowest temperature regions of the enclosure – generally toward the bottom and away from high temperature components.

Include the power dissipation of the filter along with all the other components located in the enclosure to determine the internal temperature rise and cooling requirements of the enclosure.

Refer to Article 430 Table 430.91 of the National Electrical code for the selection of the appropriate enclosure Type Number for your application.

Grounding

 WARNING	<p>The filter must always be grounded with a grounding conductor connected to ground terminals.</p>
	<p>For open panel units, ensure a 2" x 2" area is cleaned of paint and varnish on lower mounting bracket for ground connection.</p>
	<p>On NEMA 3R enclosures, CAB-26AP and larger, no live parts shall be mounted below 8 inches from the bottom of the enclosure</p>

For cable shield grounding follow the drive manufactures recommendations.

Grounding and Ground Fault Protection

The filter must always be grounded with a grounding conductor connected to all ground terminals.

Due to high leakage currents associated with variable frequency drives, ground fault protective devices do not necessarily operate correctly when placed ahead of a Matrix Filter feeding a drive. When using this type of device, its function should be tested in the actual installation.

Location & Spacing

Open panel filters are designed for mounting in the customer's enclosure. Include the power dissipation of the filter along with all the other components located in the panel to determine the internal temperature rise and cooling requirements of the enclosure. A general guideline is to allow a side clearance of four (4) inches and a vertical clearance of six (6) inches for proper heat dissipation and access within the enclosure. Clearances may be less if proper ventilation exists. Filter components must operate within temperatures specified in this manual or filter operating life will be compromised. Also, be aware of minimum electrical clearances as defined by the appropriate system safety standard(s). Open panel Matrix AP Filters generate heat and should be positioned away from heat sensitive components. Ensure that proper panel orientation is maintained. Keep the capacitors away from reactor heat flow. Avoid locations where the filter would be subjected to excessive vibrations. Locate the filter as close to the drive as possible.

General purpose NEMA 1/2, and NEMA 3R enclosed filters are designed for floor mounting in an environment suitable for the enclosure type. Do not install in or near a corrosive environment. Avoid locations where the filter would be subjected to excessive vibrations. Allow a minimum side and back clearance of eight (8) inches and front clearance of thirty-six (36) inches for proper heat dissipation and access. For lower ambient temperatures and increased air flow clearance distances can be reduced.

Over Temperature Interlock

An over temperature interlock circuit should be used in conjunction with thermal switch to turn off the drive to prevent filter damage due to abnormal operating conditions. The temperature switch is normally closed and will open when an internal reactor temperature of 180°C is reached. See Table 3-1 below for contact rating information and the drive user manual for interconnection information.

Table 3-1: Over Temperature Switch

NC Switch opens at 180 Deg. +/- 5 Deg. C		
Current Amps	Voltage	Contact Load
6	120 AC	Resistive Loads
3	120 AC	Inductive Loads
3	240 AC	Resistive Loads
2.5	240 AC	Inductive Loads
8	12 VDC	Resistive Loads
4	24 VDC	Resistive Loads

MTE highly recommends the use of the over temperature switch to prevent damage to the filter in rare instances of overheating from abnormal operating conditions.

Power Wiring Connection

 WARNING	<p>Input and output power wiring to the filter should be performed by authorized personnel in accordance with the NEC and all local electrical codes and regulations.</p> <p>Cable lugs and mounting hardware are provided by the customer.</p>
	<p>Any extremely low or high resistance readings indicate miswiring and may result in damage to filter components if not corrected.</p>
	<p>On NEMA 3R enclosures, CAB-26AP and larger, no live parts shall be mounted below 8 inches from the bottom of the enclosure.</p>

Verify that the power source to which the filter is to be connected is in agreement with the nameplate data on the filter. A fused disconnect switch or circuit breaker should be installed between the filter and its source of power in accordance with the requirements of the NEC and all local electrical codes and regulations. Refer to the drive user manual for selection of the correct fuse rating and class.

For panel mounted filter applications, interconnection between the filter, its power source, the cap-panels, and the drive is shown in Figure 3-2 (p12).

Wire gauge range and terminal torque requirements as well as selecting conductors that interconnect the HMR and capacitor assemblies are shown in Table 3-3 (p19) for 240V, Table 3-4 (p20) for 380V - 600V, and Table 3-5 (p22) for 690V.

Refer to the drive user manual for instructions on interconnecting the drive and motor and the correct start-up procedures for the drive.

The filter is designed for use with copper conductors with a minimum temperature rating of 75 degrees C.

For filters supplied in general purpose NEMA 1/2 & NEMA 3R cabinets, interconnection between the filter, its power source, and the drive is shown in Figure 3-3 (p13).

Wiring Checks

Using Figure 3-1 (p11), visually check the wired components to confirm, verify, and correct wiring. Then, with a multi meter check phase to phase isolation using the 100 K ohm range. The multi meter will read the parallel equivalent of the bleeder resistors after the capacitors initially charge. All phase to phase resistance values should be the same.

Check for the Following Faults:

- Capacitor shorted
- Capacitor bus not connected
- Capacitor bus to chassis short
- Paralleling wiring errors

Basic Schematic Diagram

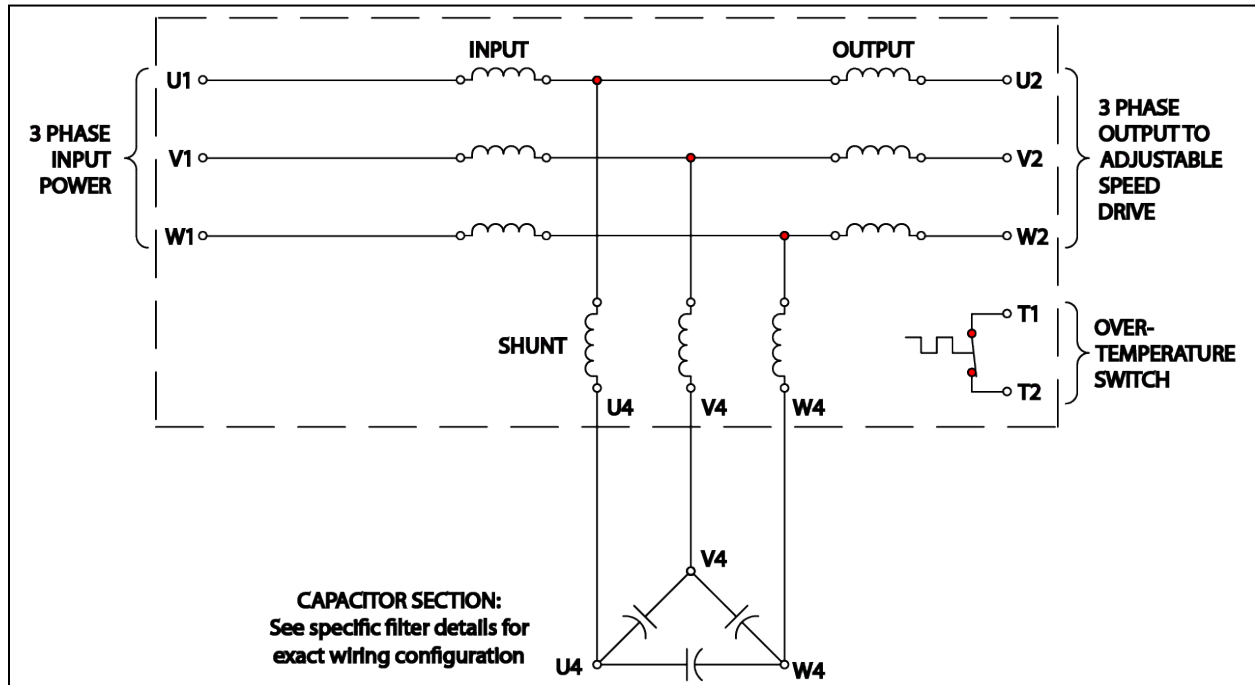

Figure 3-1: Basic Schematic Diagram

Note: Drawing depicts delta configuration for capacitors, 690V filters are connected in a WYE configuration.

Open Panel Unit Interconnection Diagram

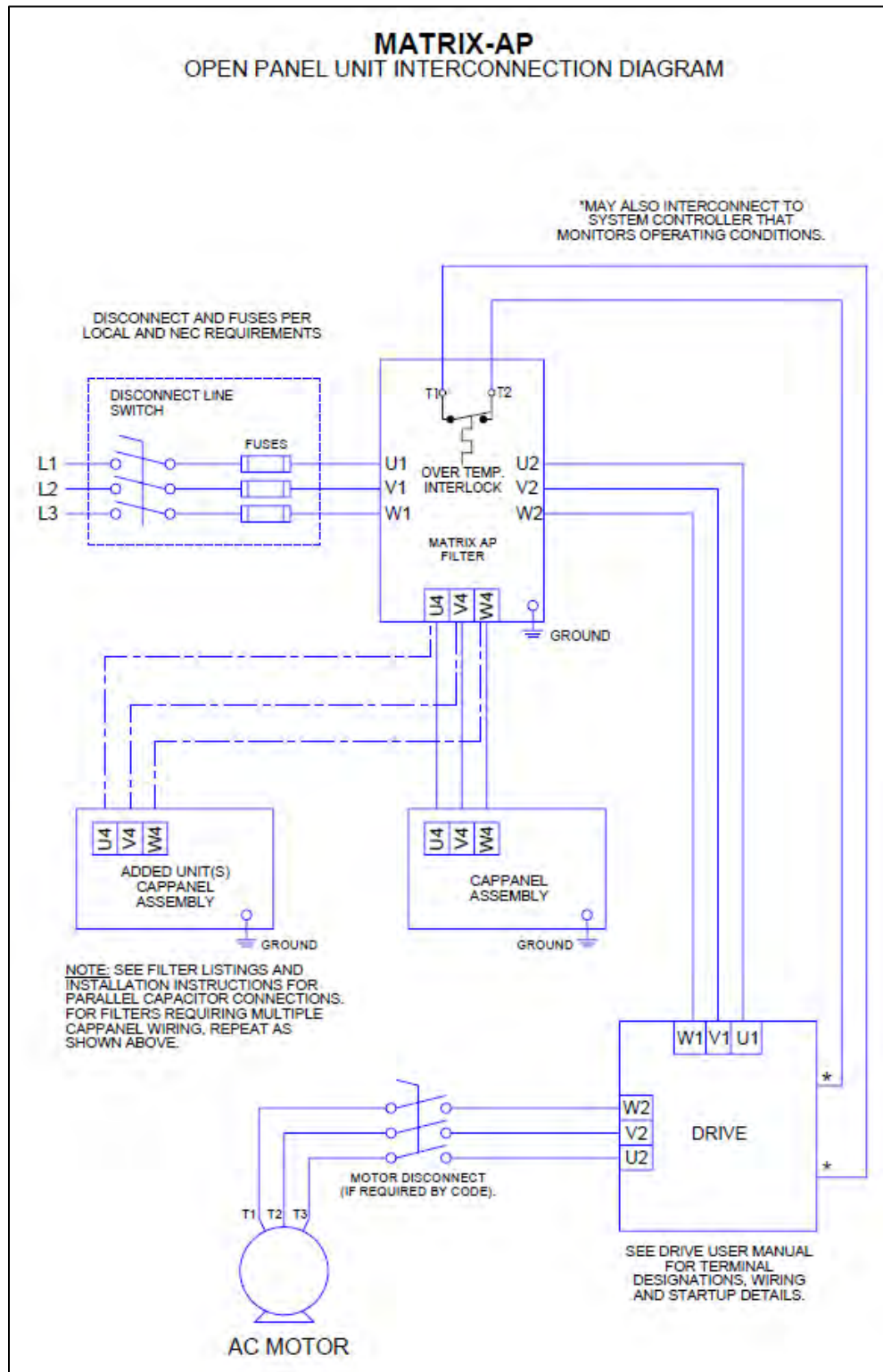

Figure 3-2: Open Panel Interconnection

Enclosed Unit Interconnection Diagram

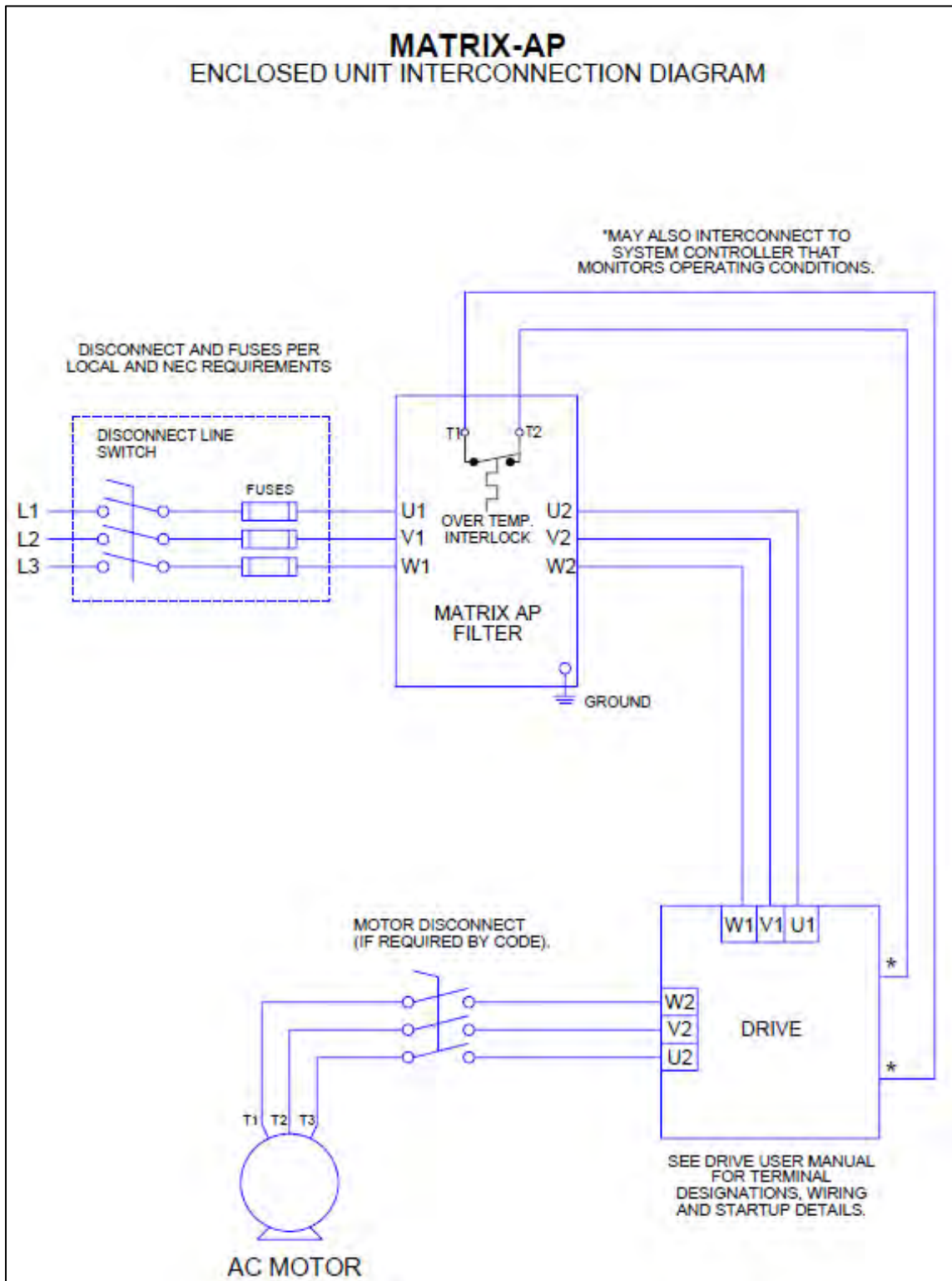

Figure 3-3: Enclosed Interconnection

Contactor Options

Option – 002

Capacitor Contactor

This option provides a contactor to disconnect the filter capacitor bank when the drive is not running. The contactor is supplied with NO/NC auxiliary contacts. The contactor coil and auxiliary contacts are wired to a customer terminal block. See page 18 for contactor coil switching characteristics. This option is provided pre-wired complete for enclosed filters and as loose parts for open panel filters.

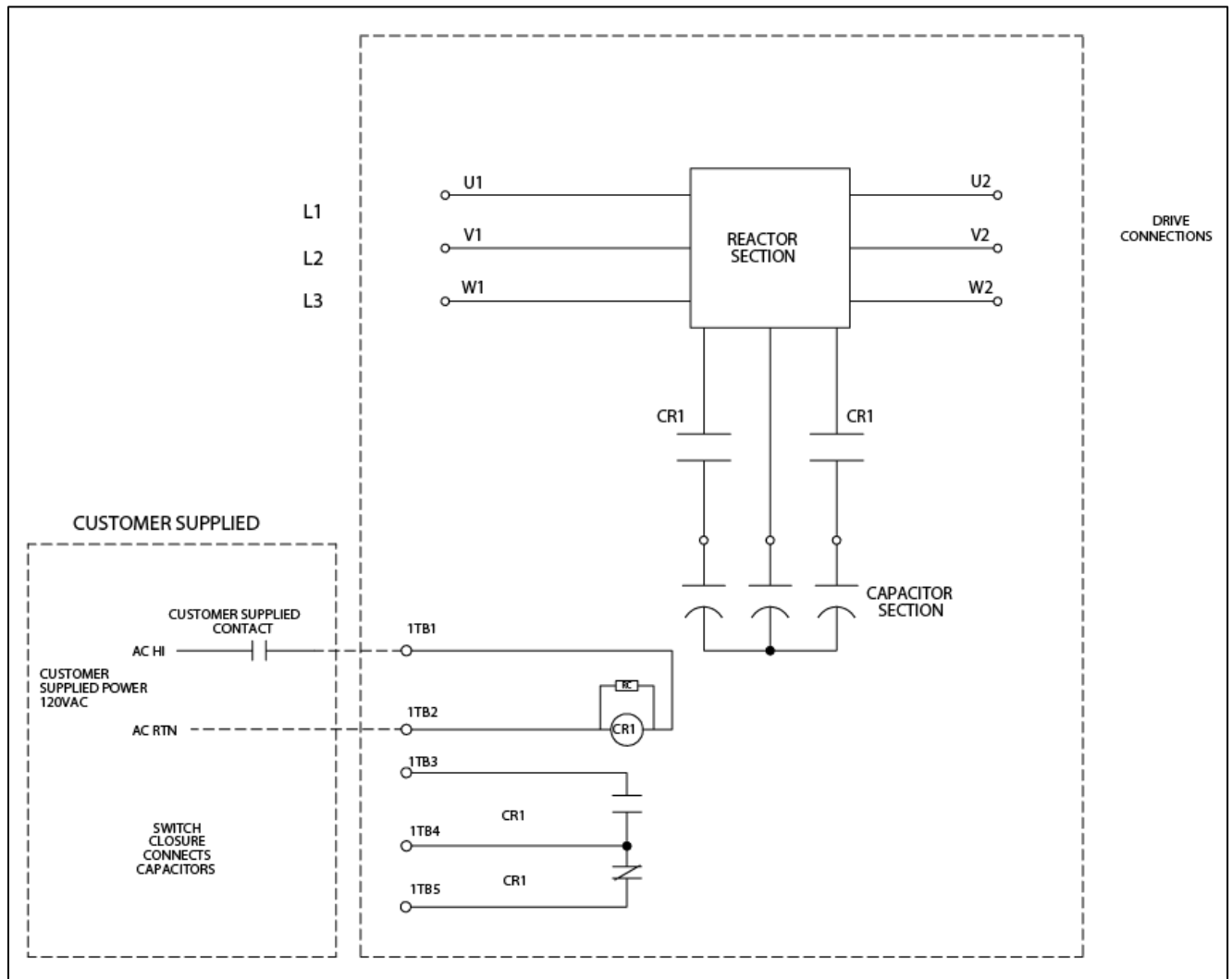

Figure 3-4: Contactor Options – 002

The above contactor option diagram is provided to help understand the circuit function and does not reflect actual circuit wiring.

Contactor Options

Option – 009

Capacitor Contactor with adjustable pick up and drop out

This option provides a contactor to disconnect the filter capacitor bank based on the motor load current. Two current operated switches provide independent adjustment of the pick-up and drop out current levels. The switches are preset at the factory for pick up at 35% and drop out at 20% of the filter output current rating. This option is only available for enclosed filters.

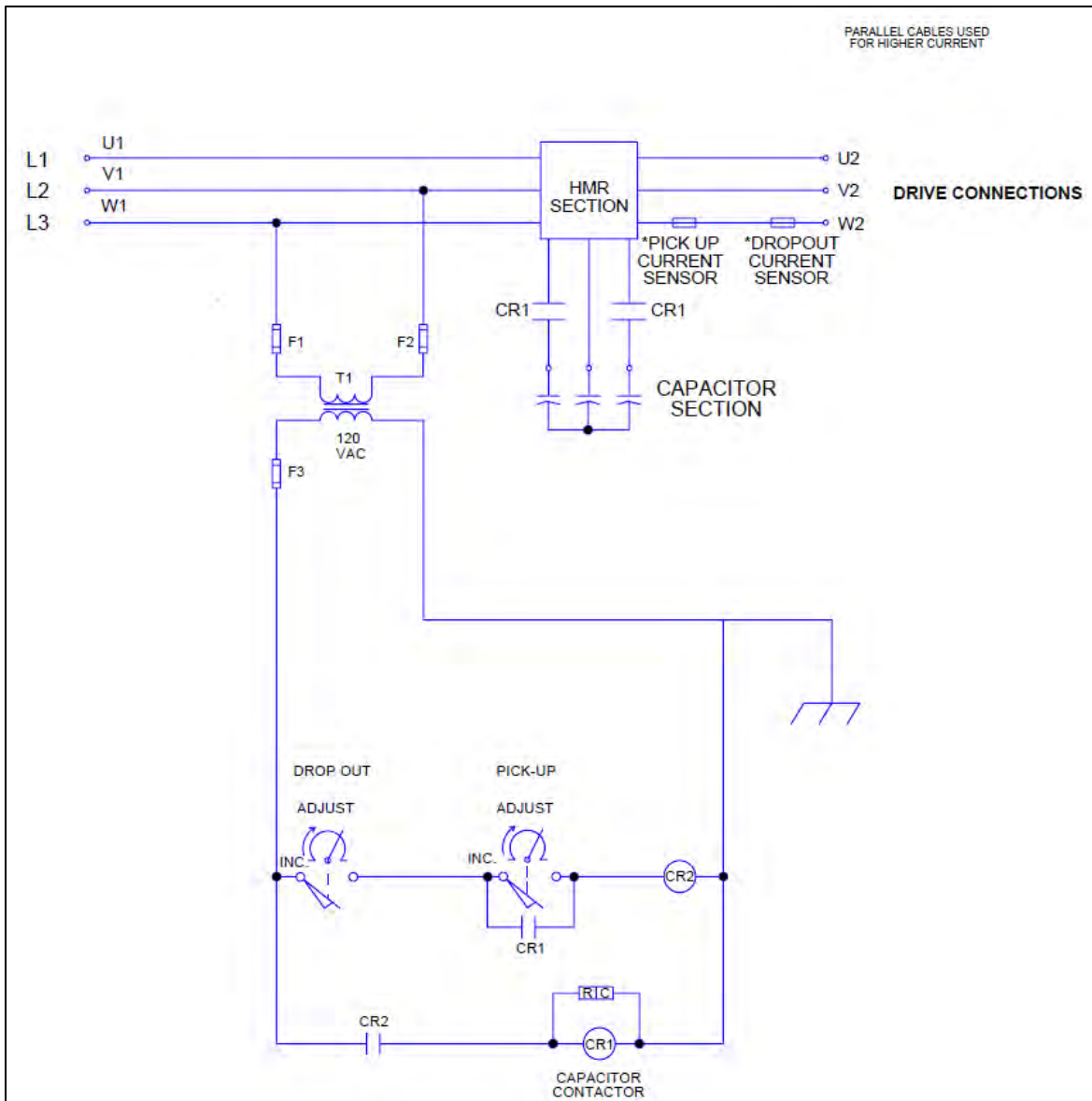

Figure 3-5: Contactor Option – 009

The above contactor option diagram is provided to help understand the circuit function and does not reflect actual circuit wiring.

Contactor Options

Option – 012

Capacitor contactor with control transformer

This option provides a control transformer to power the capacitor contactor. The contactor is provided with NO/NC auxiliary contacts. For filter ratings 165 amps and above a pilot relay is also provided to limit inrush current below 0.60 amps. Connections are wired to a customer terminal block. This option is only available for enclosed filters.

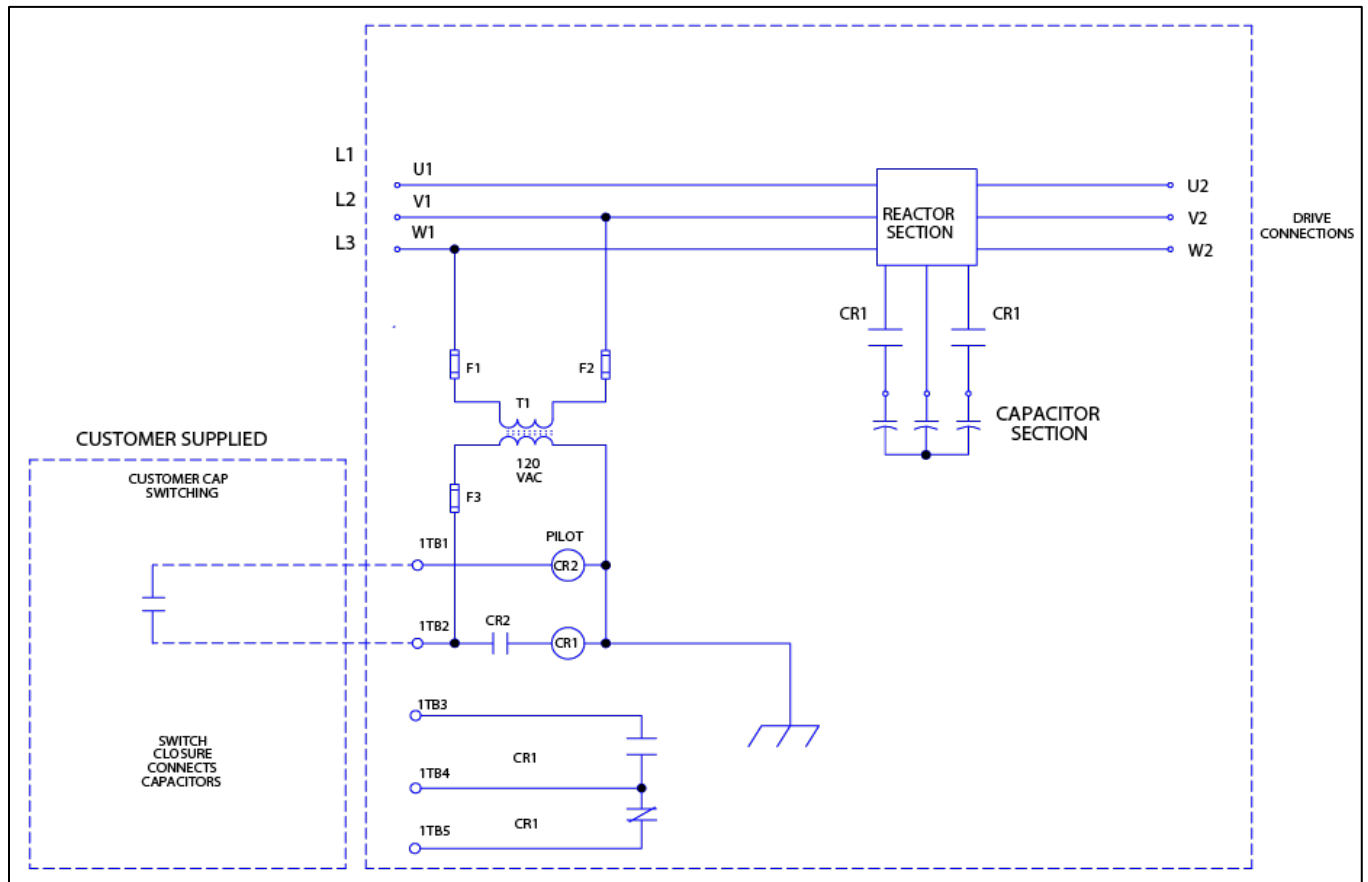

Figure 3-6: Contact Option – 012

The above contactor option diagram is provided to help understand the circuit function and does not reflect actual circuit wiring.

Contactor Options

Option – 013

Filter bypass and capacitor contactor with control transformer

This option provides a 120 VAC control transformer to power the capacitor and bypass contactors. Contactors are provided with NO/NC auxiliary contacts. For filter ratings 44 amps and above pilot relays are also provided to limit inrush currents below 0.60 amps. A jumper selection provides single contact switching for normal bypass control with capacitor removal. Connections are wired to a customer terminal block. To incorporate this option for a selected filter current rating use the part numbers shown below and select the option list price from the table below. This option is only available for enclosed filters.

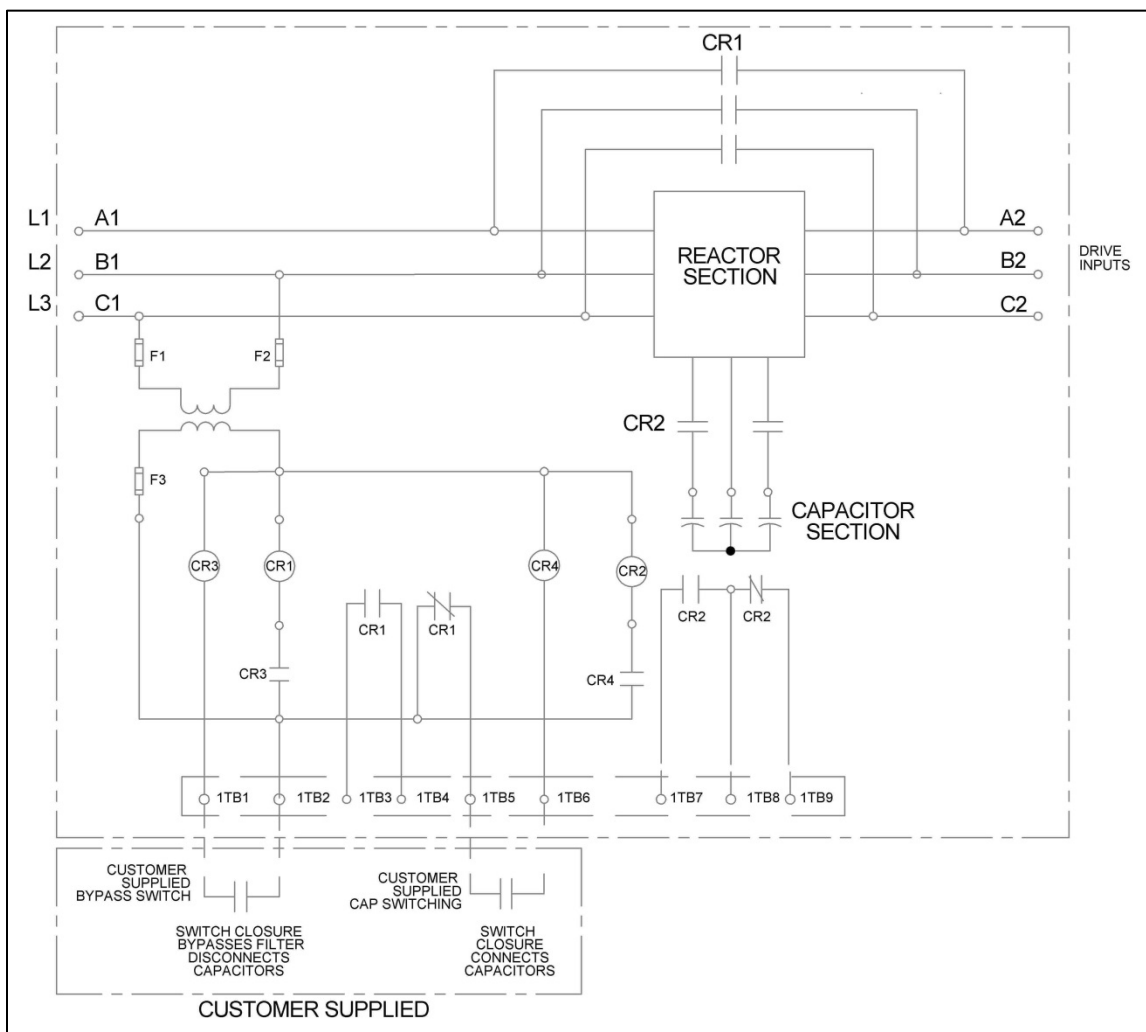

Figure 3-7: Contact Option – 013

The above contactor option diagram is provided to help understand the circuit function and does not reflect actual circuit wiring.

Contactor Coil Switching Currents

Option – 002

The following table indicates the 120 VAC 50/60 Hz current required to switch and hold the various size contactors used in Matrix AP Filter capacitor switching and bypass options. This data is provided to select the proper switch rating to remotely control the contactor and is consistent for the 208V-240V, 380V-415V, 480V, and 600V units.

Contactor Currents for 120 VAC 60 Hz coils.

Table 3-2: Contactor Coil Switching Currents

Matrix AP filter current Rating AMPS	Capacitor Contactor Option 002 AMPS	
	<i>INRUSH</i>	<i>SEALED</i>
6	0.341	0.054
8	0.341	0.054
11	0.341	0.054
14	0.341	0.054
21	0.341	0.054
27	0.341	0.054
34	0.341	0.054
44	0.341	0.054
52	0.341	0.054
66	0.341	0.054
83	0.341	0.054
103	0.341	0.054
128	0.922	0.064
165	1.70	0.304
208	1.70	0.304
240	2.00	0.42
320	1.41	0.025
403	1.41	0.025
482	2.08	0.036
636	2.08	0.036
786	3.75	0.036
850	3.75	0.036
1000	3.75	0.036
1200	3.75	0.036

Torque Ratings Matrix AP 208V-240V

Table 3-3: Torque Ratings 208V-240V

Filter Rating (Amps)	Matrix AP HMR Terminals			Cap-panel Terminals U4-V4-W4		
	Input /Output Power U1-V1-W1 / U2-V2-W2		U4-V4-W4 interconnect Cap-panel	208V-240V Capacitor/ Cap-panel Part Number	Minimum Interconnect Wire Gauge (AWG)	Terminal Torque (in-lbs.)
	Wire Range (AWG)	Terminal Torque (in-lbs.)	Terminal Torque (in-lbs.)			
6	14 - 6	16	16	CAP-352TP	14	23
8	14 - 6	16	16	CAP-352TP	14	23
11	14 - 6	16	16	CAP-366TP	14	23
14	14 - 6	16	16	CAP-342TP	14	23
21	14 - 6	16	16	CAP-369TP	14	23
27	14 - 6	16	16	CAP-356TP	14	23
34	14 - 6	16	16	CAP-357TP	12	23
44	14 - 6	16	16	CAP-373TP	12	23
52	14 - 6	16	16	CAP-374TP	10	23
66	18 - 4	16	16	CAP-375TP	10	23
83	Flat copper tab	16	16	CAP-377TP	10	23
103	Flat copper tab	16	16	CAP-358TP CAP-359TP	10	23
128	Flat copper tab	16	16	CAP-348TP CAP-358TP	10	23
165	Flat copper tab	16	16	CAP-358TP CAP-376TP	10	23
208	Flat copper tab	16	16	(2) CAP-376TP	8	23
240	Flat copper tab	16	16	CAPPANEL-153	4	60
320	Flat copper tab	16	16	CAPPANEL-154	2	60
403	Flat copper tab	16	16	CAPPANEL-155	2	60

Note: Cap-panel interconnect wiring specification according to UL508 75° C Table.

Note: To prevent flexing or bending of the coil windings attached to Matrix AP HMR Flat copper terminal tabs, use two wrenches to tighten customer provided cable mounting hardware.

Torque Ratings Matrix AP 380V-415V, 480V, 600V

Table 3-4: Torque Ratings 380V-415V, 480V, 600V

Filter Rating (Amps)	Matrix AP HMR Terminals			Cap-panel Terminals U4-V4-W4				
	Input /Output Power U1-V1-W1 / U2-V2-W2		U4-V4-W4 interconnect Cap-panel	380V-415V Capacitor/ Cap-panel Part Number	480V Capacitor/ Cap-panel Part Number	600V Capacitor/ Cap-panel Part Number	Minimum Interconnect Wire Gauge (AWG)	Terminal Torque (in-lbs.)
	Wire Range (AWG)	Terminal Torque (in-lbs.)	Terminal Torque (in-lbs.)					
6	14 - 6	16	16	CAP-350TP	CAP-338TP	CAP-361TP	14	23
8	14 - 6	16	16	CAP-351TP	CAP-339TP	CAP-362TP	14	23
11	14 - 6	16	16	CAP-352TP	CAP-349TP	CAP-363TP	14	23
14	14 - 6	16	16	CAP-353TP	CAP-340TP	CAP-364TP	14	23
21	14 - 6	16	16	CAP-342TP	CAP-341TP	CAP-365TP	14	23
27	14 - 6	16	16	CAP-354TP	CAP-342TP	CAP-366TP	14	23
34	14 - 6	16	20	CAP-355TP	CAP-343TP	CAP-367TP	12	23
44	18 - 4	16	20	CAP-356TP	CAP-344TP	CAP-368TP	12	23
52	Flat copper tab	N/A	20	CAP-357TP	CAP-345TP	CAP-369TP	10	23
66	Flat copper tab	N/A	50	CAP-358TP	CAP-346TP	CAP-370TP	10	23
83	Flat copper tab	N/A	16	CAP-359TP	CAP-347TP	CAP-371TP	10	23
103	Flat copper tab	N/A	16	CAP-360TP	CAP-348TP	567(C)	8	23/60
128	Flat copper tab	N/A	N/A	621(C)	555(C)	568(C)	8	60
165	Flat copper tab	N/A	N/A	544(C)	557(C)	570(C)	6	60
208	Flat copper tab	N/A	N/A	543(C)	545(C)	572(C)	4	60
240	Flat copper tab	N/A	N/A	595(C)	544(C)	574(C)	4	60
320	Flat copper tab	N/A	N/A	596(C)	543(C)	576(C)	2	60
403	Flat copper tab	N/A	N/A	597(C)	562(C)	578(C)	1/0	60
482	Flat copper tab	N/A	N/A	595(C)	544(C)	574(C)	4	60
				595(C)	544(C)	574(C)	4	60
636	Flat copper tab	N/A	N/A	596(C)	543(C)	576(C)	2	60
				596(C)	543(C)	576(C)	2	60
786	Flat copper tab	N/A	N/A	597(C)	562(C)	578(C)	1/0	60
				597(C)	562(C)	578(C)	1/0	60
850	Flat copper tab	N/A	N/A	596(C)	543(C)	N/A	2	60
				596(C)	543(C)	N/A	2	60
				595(C)	544(C)	N/A	4	60

Filter Rating (Amps)	Matrix AP HMR Terminals			Cap-panel Terminals U4-V4-W4				
	Input /Output Power U1-V1-W1 / U2-V2-W2		U4-V4-W4 interconnect Cap-panel	380V-415V Capacitor/ Cap-panel Part Number	480V Capacitor/ Cap-panel Part Number	600V Capacitor/ Cap-panel Part Number	Minimum Interconnect Wire Gauge (AWG)	Terminal Torque (in-lbs.)
	Wire Range (AWG)	Terminal Torque (in-lbs.)	Terminal Torque (in-lbs.)					
1000	Flat copper tab	N/A	N/A	596(C)	543(C)	N/A	2	60
				596(C)	543(C)	N/A	2	60
				596(C)	561(C)	N/A	2	60
1200	Flat copper tab	N/A	N/A	597(C)	562(C)	N/A	1/0	60
				597(C)	562(C)	N/A	1/0	60
				597(C)	562(C)	N/A	1/0	60
1600	Flat copper tab	N/A	N/A	N/A	563(C)	N/A	1/0	60
				N/A	563(C)	N/A	1/0	60
				N/A	563(C)	N/A	1/0	60
				N/A	563(C)	N/A	1/0	60
2000	Flat copper tab	N/A	N/A	N/A	563(C)	N/A	1/0	60
				N/A	563(C)	N/A	1/0	60
				N/A	563(C)	N/A	1/0	60
				N/A	563(C)	N/A	1/0	60
				N/A	563(C)	N/A	1/0	60
2300	Flat copper tab	N/A	N/A	N/A	562(C)	N/A	1/0	60
				N/A	562(C)	N/A	1/0	60
				N/A	562(C)	N/A	1/0	60
				N/A	562(C)	N/A	1/0	60
				N/A	562(C)	N/A	1/0	60
				N/A	562(C)	N/A	1/0	60

Note: Cap-panel numbers designated with “(C)” as a suffix indicate cap-panels will be either –xxx or –xxxC.

Note: Cap-panel interconnect wiring specification according to UL508 75° C Table.

Note: To prevent flexing or bending of the coil windings attached to Matrix AP HMR Flat copper terminal tabs, use two wrenches to tighten customer provided cable mounting hardware.

Torque Ratings Matrix AP 690V

Table 3-5: Torque Ratings - 690V

Filter Rating (Amps)	Matrix AP HMR Terminals			Cap-panel Terminals U4-V4-W4		
	Input /Output Power U1-V1-W1 / U2-V2-W2		U4-V4-W4 interconnect Cap-panel	690V Capacitor/ Cap-panel Part Number	Minimum Interconnect Wire Gauge (AWG)	Terminal Torque (in-lbs.)
	Wire Range (AWG)	Terminal Torque (in-lbs.)	Terminal Torque (in-lbs.)			
52	Flat copper tab	N/A	N/A	CAPPANEL-622(C)	12	60
66	Flat copper tab	N/A	N/A	CAPPANEL-612(C)	10	60
83	Flat copper tab	N/A	N/A	CAPPANEL-613(C)	10	60
103	Flat copper tab	N/A	N/A	CAPPANEL-615(C)	8	60
128	Flat copper tab	N/A	N/A	CAPPANEL-617(C)	8	60
165	Flat copper tab	N/A	N/A	CAPPANEL-619(C)	8	60
208	Flat copper tab	N/A	N/A	CAPPANEL-614(C)	8	60
				CAPPANEL-616(C)	8	60
240	Flat copper tab	N/A	N/A	CAPPANEL-616(C)	8	60
				CAPPANEL-617(C)	8	60
320	Flat copper tab	N/A	N/A	CAPPANEL-618(C)	6	60
				CAPPANEL-618(C)	6	60
403	Flat copper tab	N/A	N/A	CAPPANEL-614(C)	8	60
				CAPPANEL-618(C)	6	60
				CAPPANEL-618(C)	6	60
482	Flat copper tab	N/A	N/A	CAPPANEL-618(C)	6	60
				CAPPANEL-618(C)	6	60
				CAPPANEL-618(C)	6	60
636	Flat copper tab	N/A	N/A	CAPPANEL-620(C)	4	60
				CAPPANEL-621(C)	4	60
				CAPPANEL-621(C)	4	60

Note: Cap-panel numbers designated with “(C)” as a suffix indicate cap-panels will be either –xxx or –xxxC.

Note: Cap-panel interconnect wiring specification according to UL508 75° C Table.

Note: To prevent flexing or bending of the coil windings attached to Matrix AP HMR Flat copper terminal tabs, use two wrenches to tighten customer provided cable mounting hardware.

4. START UP

Startup Checklist

Safety Precautions



Before startup, observe the following warnings and instructions:

 WARNING	<p>Internal components of the filter are at line potential when the filter is connected to the drive. This voltage is extremely dangerous and may cause death or severe injury if you come in contact with it.</p>
	<p>Remove all power to the Matrix AP filter in compliance to standardized 26 CFR 1920.147 lockout/tagout policies. After removing power, allow at least five minutes to elapse and verify that the capacitors have discharged to a safe level before contacting internal components. Connect a DC voltmeter across the capacitor terminals and ensure that the voltage is at a safe level. Start with the meter on the highest scale and progressively switch to a lower scale as the indicated voltage falls below the maximum value of the scale used.</p>
	<p>Use extreme caution to avoid contact with line voltage when checking for power. INJURY OR DEATH MAY RESULT IF SAFETY PRECAUTIONS ARE NOT OBSERVED.</p>
	<p>Damage to equipment may occur if the drive startup procedures are not observed.</p>

Sequence of Operation

1. Read and follow safety precautions.
2. After installation, ensure that:
 - All filter ground terminals are connected to ground.
 - Power wiring to the utility, drive and motor is in accordance with the power wiring connection diagrams shown in installation instructions section. Use the guidelines of Table 3-3 (p19) for 208V-240V, Table 3-4 (p20) for 380V - 600V and Table 3-5 (p22) for 690V, for power and cap-panel wire gauges.
3. Check that moisture has not condensed on the filter components. If moisture is present, do not proceed with startup until the moisture has been removed.
4. Disconnect the filter output from the drive.
5. Connect the filter to the utility.
6. Confirm that line voltage is present at the input terminals (U1, V1, W1) of the filter.
7. Confirm that drive voltage is present at the output terminals (U2, V2, W2) of the filter and that it is equal to 1.05 times the input voltage with capacitors in circuit.
8. Using a clamp on Amp meter, check input phase currents to verify they are within a 5% match to each other and approximately 30% of filter current rating.
9. Remove power and verify that **NO VOLTAGE** is present on the filter terminals.
10. Connect the filter output to the drive.
11. Refer to the drive user manual for the drive startup procedure. Observe all safety instructions in the drive user manual.

5. TROUBLESHOOTING

 WARNING	<p>INJURY OR DEATH MAY RESULT IF THE DRIVE SAFETY PRECAUTIONS ARE NOT OBSERVED.</p>
	<p>When properly installed, this equipment has been designed to provide maximum safety for operating personnel. However, hazardous voltages and elevated temperatures exist within the confines of the enclosure. Servicing should therefore be performed by qualified personnel only and in accordance with OSHA Regulations.</p>
	<p>High voltage is used in the operation of this filter. Use Extreme caution to avoid contact with high voltage when operating, installing or repairing this filter. INJURY OR DEATH MAY RESULT IF SAFETY PRECAUTIONS ARE NOT OBSERVED.</p>
 Caution	<p>After removing power, allow at least five minutes to elapse and verify that the capacitors have discharged to a safe level before contacting internal components. Connect a DC voltmeter across the capacitor terminals or terminals U1, V1 or V1, W1 and ensure that the voltage is at a safe level.</p>

To aid in troubleshooting, a basic schematic diagram, two interconnection diagrams, and a troubleshooting guide that lists potential problems and solutions are included:

Figure 3-1: Basic Schematic Diagram (p11)

Figure 3-2: Open Panel Interconnection (p12)

Figure 3-3: Enclosed Interconnection (p13)

Table 5-2: Troubleshooting Guide (p28)

Matrix AP Performance Data

For specific product performance specifications, reference Table 5-1 below:

Table 5-1: Performance Specifications

Service Load Condition	Load: 6-pulse rectifier only
Input Voltage	208V-240V +/- 10%; 60 + 0.75 Hz; 3-phase 380V - 415V +/- 10%; 50 + 0.75Hz; 3-phase 480V +/- 10%; 60 + 0.75Hz; 3-phase 600V +/- 10%; 60 + 0.75Hz; 3-phase 690V +/- 10%; 50 + 0.75Hz; 3-phase
Maximum THID	8% @ 30% Load; 5% @ Full Load
Maximum Ambient Temperature	-40C to +50C Open Panel Filters -40C to +40C – 45C Enclosed Filters -40C to +90C Storage
Insertion Loss @ Full Load	<4%
Efficiency	97% - 99%
Altitude without derating	3,300 feet above sea level
Relative Humidity	0% to 95% non-condensing
Current Rating	150% for 1 minute

Generator sizing note: Generator sizing is best completed by sizing programs or help from a generator manufacturing representative. Identify every load type and size that will be powered from the generator. If non-linear loads are present the generator may need to be oversized.

Generator rated KVA minimum load \geq Matrix rated current $\times \sqrt{3}$ generator voltage

FLA load current \leq Matrix filter rated current

Notes (SCCR):

The Short Circuit Current Rating (SCCR) is not required under Exception No.1 of UL508A SB4.2.1 effective 4/25/06. This exception also applies to all the Contactor Options (002, 009, 012, and similar), where the Contactors are separated from the Main Power path by exempt components (such as Reactors) of sufficient Impedance, which is assured in case of the Reactors that are integral components of our Filter.

Matrix AP Harmonic Filter Field Checks

1. Read and understand the Matrix AP Technical Reference Manual which can be downloaded at www.mtecorp.com/matrix-ap-documentation/. Locate figures and drawings for your particular filter and identify the terminal locations.
2. Disconnect all power and remove input power wiring from U1, V1, W1 terminals.
3. Remove VFD drive power connections from filter terminals U2, V2, W2 and any contactor or temperature switch wiring. (For filters using control transformers: remove power fuses on top of transformer.)
4. Visually inspect filter terminals and wiring lugs for signs of heat and corrosion. **Contact factory if any wires appear to be missing or cut!**
5. Inspect the U4, V4, W4 capacitor interconnect terminals and wiring.
6. Visually inspect all capacitors for signs of case deformation, bowing of the top, leaking oil or terminal damage. Note the CAP- # and date code of any damaged capacitors.
7. Using a multi meter set to read 100K ohms check:
 - a. Phase to phase U1-V1-W1-U1 (mechanically activate contactor if present) after reactor and caps charge reading should be about 40K (total equivalent breeder resistance value) and should be the same for each phase. Open circuit or very low readings indicate a problem.
 - b. Phase to chassis U1- case, V1-case, W1- case; low readings indicate a ground fault problem.
8. Ensure the “disconnect” is safe then wire the utility power to U1, V1, W1.
9. Apply power and verify that proper output voltage is present on U2, V2, and W2.
10. Using a clamp on amp meter read the filter input current:
 - a. Readings will be 0.5 of the capacitor current listed in the Matrix AP Technical Reference Manual found at www.mtecorp.com/matrix-ap-documentation/ (mechanically activate the contactor if the filter is equipped with one). Readings should be the same (+/- 5%) for all phase currents; **contact the factory if currents are out of tolerance!**
 - b. Open contactor readings will show zero current for all phases.
11. Disconnect filter power and wire the VFD to U2, V2, and W2 as well as any control wiring to the filter contactor or temperature switch. Replace any control transformer fuses. Follow the drive power startup guidelines in the drive manufacturer’s user manual.

Table 5-2: Troubleshooting Guide

PROBLEM:	Line voltage is not present at the filter output terminals.
Possible cause:	Power to the filter is turned off.
Solution:	Turn power on.
Possible cause:	One or more external line fuses are blown.
Solution:	Verify the continuity of line fuses in all phases. Replace as necessary.
PROBLEM:	Full Load Harmonic current distortion exceeds 5% on one or more phases at full load.
Possible cause:	The capacitor assembly has not been connected.
Solution:	Check interconnection of capacitor assembly per the following: Figure 3-1: Basic Schematic Diagram (p11) Figure 3-2: Open Panel Interconnection (p12) Figure 3-3: Enclosed Interconnection (p13)
Possible cause:	A capacitor has failed.
Solution:	Inspect the tops of all capacitors for bowing. Replace failed capacitors.
Possible cause:	Source impedance is less than 1.5%.
Solution:	Add a minimum 1.5% impedance line reactor to the filter input.
Possible cause:	Input source voltage harmonic distortion.
Solution:	Identify equipment causing harmonic voltage distortion and add filters as required or accept elevated THVD.
Possible cause:	Line voltage unbalance exceeds 1%.
Solution:	Balance input line voltage to 1% or less.
PROBLEM:	Filter output voltage is not within specification
Possible cause:	Filter input voltage is not within specification.
Solution:	Check the AC input line voltage and verify that it is within tolerance. Refer to the filter service conditions and performance specifications for tolerances.
Possible cause:	Source impedance is out of tolerance.
Solution:	Verify that the source impedance is within tolerance. Refer to the filter service conditions and performance specifications for tolerances.
Possible cause:	Source impedance is out of tolerance.
Solution:	Verify that the source impedance is within tolerance. Refer to the filter service conditions and performance specifications for tolerances.
Possible cause:	One or more Capacitors is damaged.
Solution:	Visually check capacitor top for distortion or doming. Check for shorts or open caps. Replace failed capacitors.
Possible cause:	Drive set up parameter does not allow for input filter
Solution:	Consult drive manufacturer to update setup to accommodate input filter.
Possible cause:	Input voltage subject to extreme transients such as switching between two voltage sources. Drive faults on over or under voltage.
Solution:	Source switching is not recommended without proper phase synchronizing or allowing reasonable time delay before transfer to new source.